

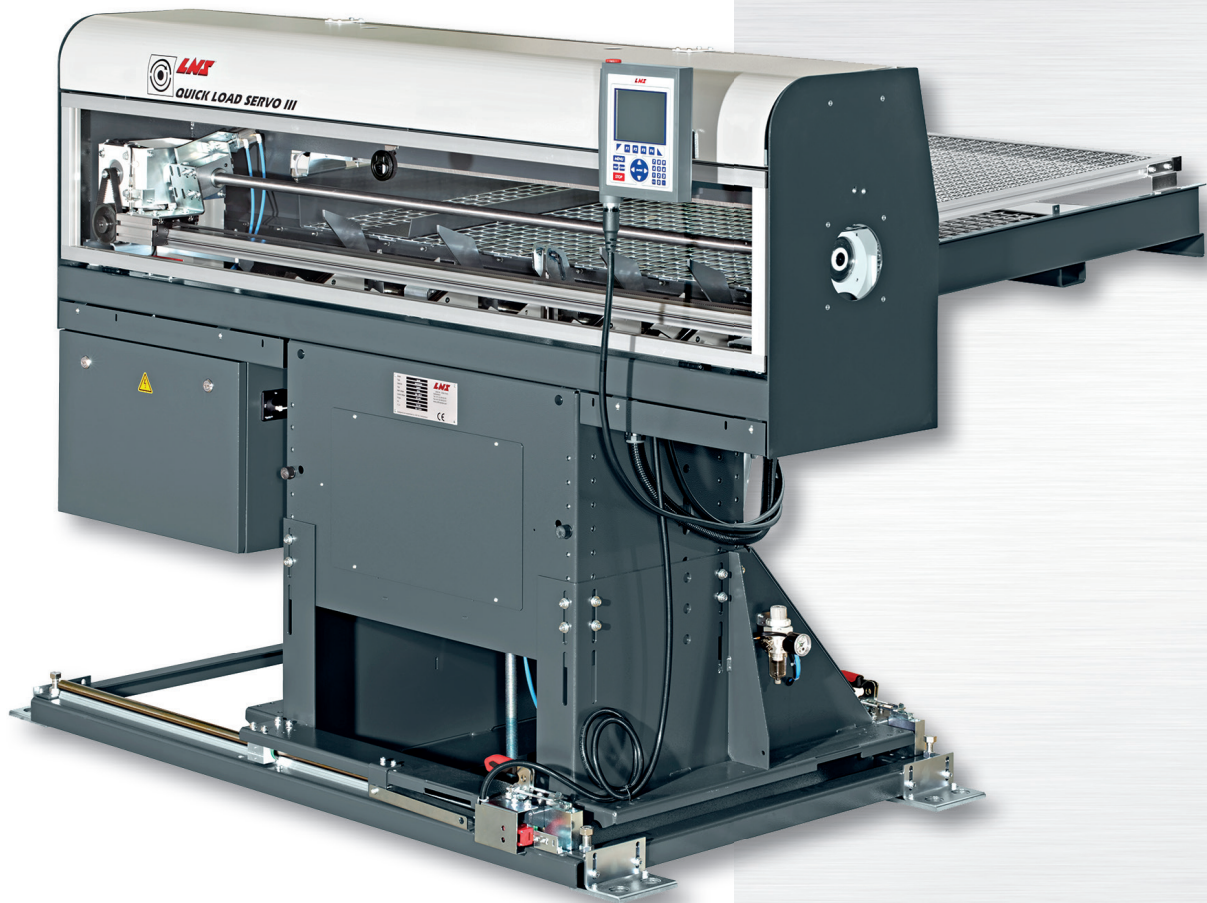

QUICK LOAD SERVO III

THE UNDISPUTED REFERENCE
FOR SHORT BAR LOADING

Diameter range: 6 – 120 mm



YOUR ONE-STOP-SHOP
FOR MACHINE-TOOL PERIPHERALS



THE UNDISPUTED REFERENCE FOR SHORT BAR LOADING

The most versatile fully-automatic short bar loader. The Quick Load Servo III offers maximum flexibility for small and medium-sized runs in the 6 to 120 mm diameter range. This bar loader can be fitted to most lathes of fixed headstocks and allows a large number of operations to be carried out in record time. In addition, due to its compact design, it occupies a minimum floorspace.



PERFORMANCES

The Quick Load Servo III's higher flexibility allows high-performance work for the most challenging applications. It also allows the available workspace to be used in the best possible way. The technical design and finishing of the machine also considerably reduces operational costs. Movements are extra fast in order to minimize non-productive time during production. The magazine is equipped with a device that allows soft and quiet loading. The rollers keep friction to a minimum, regardless of the material or quality of the bars.



CHANGING DIAMETERS

In the turning industry, speed and reliable operation are of primary concern in achieving maximum productivity. For optimizing profitability, the Quick Load Servo III enables production changeover with a few seconds only.

Production changeover is done by simply entering the new diameter using the remote control. Since the length of the remnant is known, the loading cycle for the new bar starts during machining of the last part.

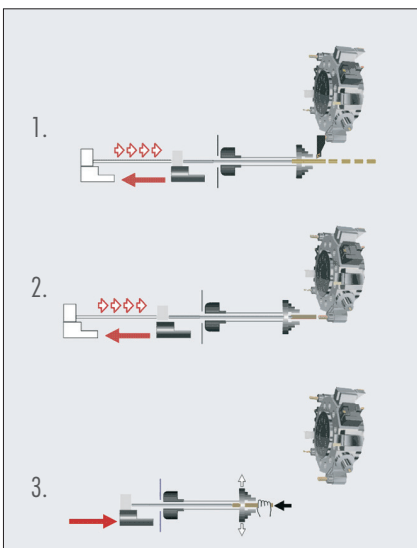

SMART POSITIONING THROUGH SERVO DRIVE

The LNS servo drive technology guarantees the Quick Load Servo III an unrivalled bar positioning precision, and allows different feeding modes to prevent the bar from hitting the turret:

1. Without a bar stop on the turret:
The barfeeder pushes and positions the material without any help from the lathe. The best accuracy is reached when the lathe uses a "pull-to-close" clamping device.
2. With a bar stop on the turret:
The barfeeder pushes the bar against the turret stop, either in final position or as the turret moves into the feedout position, all while adapting the deceleration curve to create a "soft touch" effect against the stop and preserve the mechanical elements.
3. Manual loading of shafts or premachined parts*:
When the clamping device of the lathe opens, the pusher moves in position to create a mechanical stop inside of the clamping device that is used as a reference for accurate and repeatable positioning of the material by the operator.

* This option cannot be used in lathes equipped with double channel safety interface.

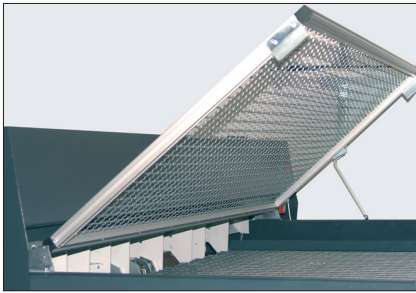

IMPORTANT RUN EQUIPMENT

In order to accommodate a broad range of diameters (6–120 mm), the Quick Load Servo III includes a wide range of equipment in the standard version, such as fully-automatic diameter control, Z or X-axis retraction, and a front or rear loading rack.

In addition, various high-value added options are available, such as adapters for profiled bars, a shaft loading kit, or a telescopic pusher.

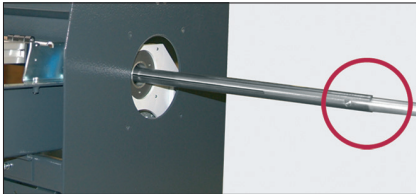

TELESCOPIC PUSHER

LNS also offers a telescopic pusher as an optional feature for the Quick Load Servo III. This extends the pusher by 500 mm in order to equip lathes with extra length or recessed spindles. This ingenious system reduces footprint to a minimum.



THE WAY IN WHICH THE BAR LOADER IS SET UP HAS AN IMPACT ON THE PERFORMANCE OF THE LATHE / MAGAZINE BAR LOADER COMBINATION

At this stage, the technician's skills, experience, and knowledge, in addition to the equipment's features, is added value.

The user-friendly remote control helps the operator to set up the unit, and provides self-diagnosis and monitoring. The LNS worldwide technical support, with direct access to qualified assistance, provides solutions without delay to any production breakdown.

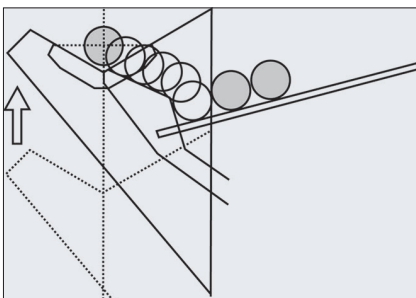

LOADING RACK

The Quick Load Servo III has a loading rack based on a lateral magazine with a depth of 1000 mm. This allows storage of eight \varnothing 120 mm bars, or 166 \varnothing 6 mm bars. Therefore long unattended production runs are possible.

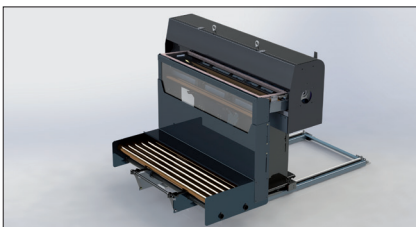

OPTIONS

The bar stocks now can be brought with a fork lift or a crane directly on the ramp, saving manpower for the heavy lifting. The loading of a new bar stock is done in masked time for maximum productivity. Thanks to the lower location, the barfeed's stability is also improved when using heavy bars, all while keeping all the original features of the QLSIII.



REMOTE CONTROL

The Quick Load Servo III's ergonomic remote control ensures simplified operations and rapid access to important information. Commands are entered using symbols, making the procedure highly intuitive.

TECHNICAL SPECIFICATIONS

YOUR ONE-STOP-SHOP FOR MACHINE-TOOL PERIPHERALS

LNS provides a full range of bar feeders, chip conveyors, coolant management systems and air filtration systems which is second to none on the market. We are known in the industry for the solid expertise we have gained over several decades in an exceptionally wide range of applications, our excellent customer service and technical support. This support is ensured by highly qualified technicians who are available at key locations throughout Europe.

Capacity		
Bar diameter	mm	ø 6 – 120 (Weight limited to 67 kg per bar)
Bar length	mm	100 – 1600 (Weight limited to 67 kg per bar)
Loading system		Side load rack
Loading capacity	mm	1000
Loading side		Front/Rear
Applications		
Type of headstock		Fixed
X or Z axis retraction	mm	600
Diameter change		
Diameter setup	sec	10 (fully automatic)
Complete change	min	2 (including pusher)
Driving system		
Motor		Servo
Drive		Notched belt
Options		
Telescopic pusher		
Shaft loading kit		
Orientation kit for square bar stocks		
Kit "heavy bars" up to 80 kg per bar stock		
⚠ The bar length cannot exceed the spindle length		

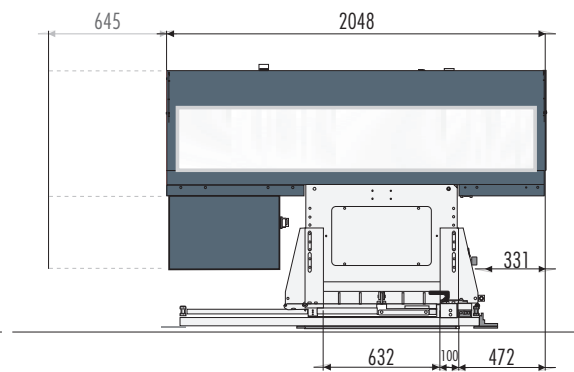
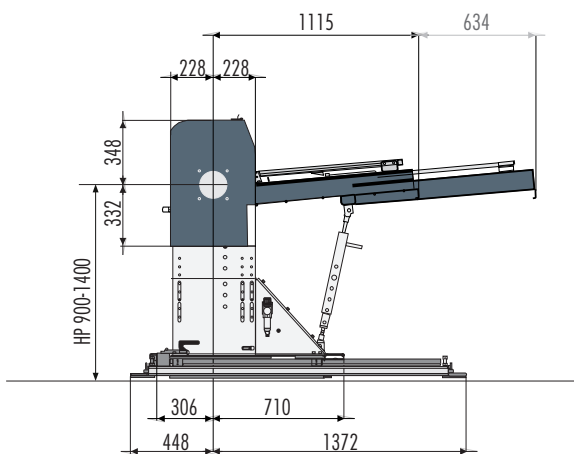

LNS SA
Route de Frinvillier
2534 Orvin
Switzerland

+41 32 358 02 00
LNS@LNS-europe.com
www.LNS-europe.com