

**The low-cost solution for
chamfering, centring and preparing
your bars!**

PB 80

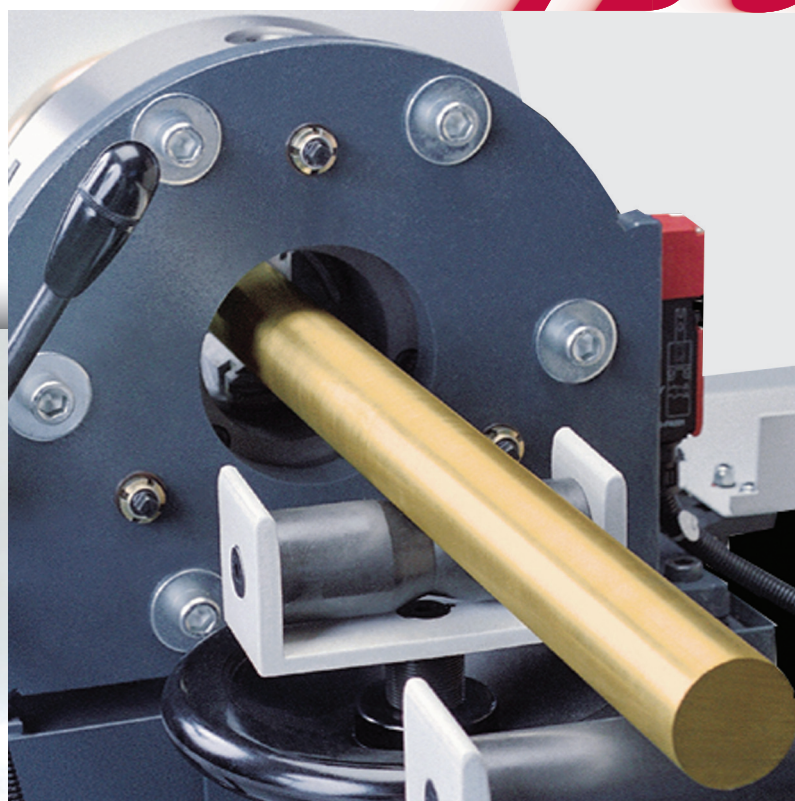

LNS[®]



LNS A MEMBER OF NUGEROL HOLDING SA

PB 80

The low-cost solution for chamfering, centring and preparing your bars!

PB 80 was especially developed to meet the specific requirements of work with bars, so it is the ideal complement for bar loaders and bar feeders. This chamfering machine provides an economical solution that adapts to three different applications: chamfering, centring and turning.

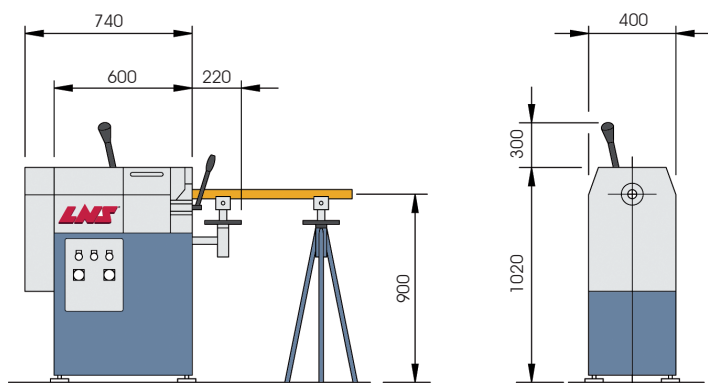

Technical specifications

30° chamfering	ø 8 - 80 mm
Turning	ø 10 - 60 mm (40 mm max. length)
Centering	ø 8 - 80 mm
Clamping system	By chuck with 3 jaws (4 jaws in option) manually actuated by key
Driving system	2 speeds motor, transmission with 2 ratios by notched belts

Performances

A choice 4 different revolution speeds is available for the optimum machining of bars from 8 to 80 mm ø in various materials.

The shavings are collected in a drawer that can be completely withdraw, this also facilitating the maintenance of the machine.

Ease of use

It is enough to actuate the lever and the rotating tool-holder head advances against the static material. The bar is then chamfered or turned according to the tool installed.

As an option, there is also a universal head called the «pencil sharpener» to chamfer bars of 8 to 50 mm ø.

Clamping of the bar

The bar is clamped into position by means of a triple-jaw chuck (for round or hexagonal bars), or a quadruple-jaw chuck (for square bars). The chucks are clamped outside the body of the machine, so that it is not necessary to open any protection panels to change diameter.

A tripod and a height-adjustable support perfectly support the bars to be machined and are adjusted by flywheels.

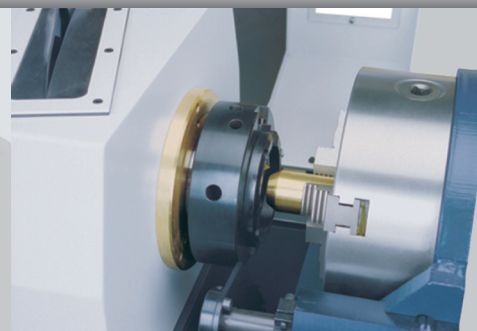
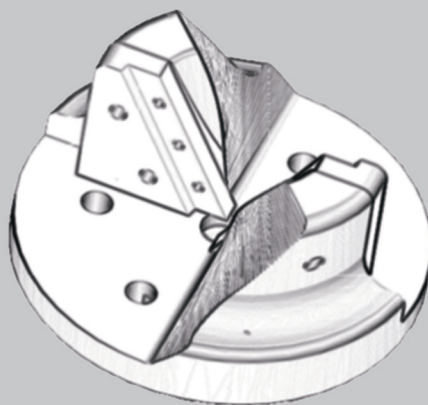

LNS SA
CH-2534 Orvin
www.Lns-europe.com

Phone +41 (0)32 358 02 00
Fax +41 (0)32 358 02 01
sales@Lns-world.com