



THE ULTIMATE MACHINING POWER

**YIH CHUAN MACHINERY
INDUSTRY CO., LTD**

HEADQUARTERS

40755 No.8, 9th Rd., Taichung Industrial Park,
Taichung, Taiwan

Tel : +886-4-2359-3351

Fax : +886-4-2359-0012

E-mail : extron@extroncnc.com

**YIH CHUAN MACHINERY
(JIAXING) INDUSTRY CO., LTD**

CHINA BRANCH

314031 No.3198, Zhongshan West Rd.,
Xiuzhou Industrial Area, Jiaxing, Zhejiang

Tel : +86-573-8279-9488

Fax : +86-573-8279-7299

E-mail : yihchuan@extroncnc.com



EXTRONCNC.com

m Series

High Rigidity
Vertical Machining Centers



EXTRON

THE ULTIMATE MACHINING POWER

With 40 years experience of manufacturing machine tools, EXTRON has continuously developed and provided creative machine tools for global customers. We're always looking for solutions to improve our products and give you the best quality, reliable machines and service.

- 3 axes adopt high rigidity box ways design which is suitable for high rigidity requirements of heavy cutting.
- German made ZF gear box is option to provide high torque output to fulfill heavy cutting capability. Also, equipped 15,000 rpm direct drive spindle provides high speed high accuracy machining application is available for option.
- Arm type tool ATC system provides smooth tool changing without delay.
- Powerful coolant nozzles around spindle featured with high pressure flush coolant design provides high performance chip removal capability while ensuring outstanding machining accuracy.



HIGH RIGIDITY VERTICAL MACHINING CENTERS

M860 / M1100
/ M1320 / M1600 / M1600L

The M series featured excellent cutting and structural rigidity along with high torque ZF gear box, high speed spindle and ATC system to achieve heavy-duty machining capability. Drilling, milling and tapping can be processed in one set-up to fulfill your requests in the future.



- The Meehanite casting structure and A-shaped column design provide solid support to efficiently enhance structure rigidity.
- The massive structure of bed, column, and table are all adopted with enforced cross ribs design that offers the best stability and precision for constantly machining.
- By carrying the weight of tool magazine and tools on casting body can enforce reliability of tool change and extend usage of tool magazine.
- Box ways are coated with specialized Turcite-B which can not only prevent slow-moving and lower abrasion, but also maintain high rigidity, low wear and noiseless along with great positioning accuracy.

Bed Structure

- One-piece wide bed structure with four box ways eliminates over-hang issue of working table to ensure optimal solid support.
- Contact surface between bed and column are carefully hand scraped to ensure optimal precision assembly and enforce structural strength.

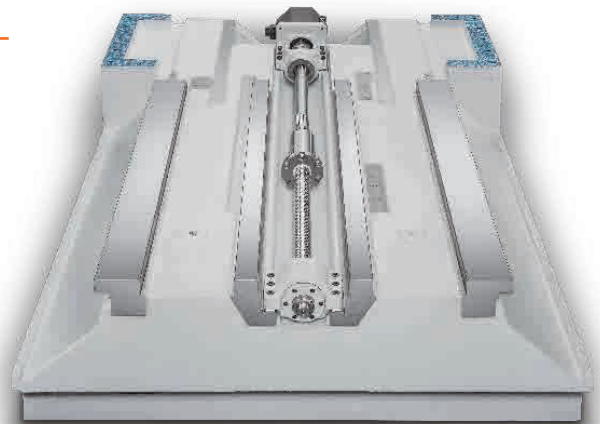

Rapid Axial System

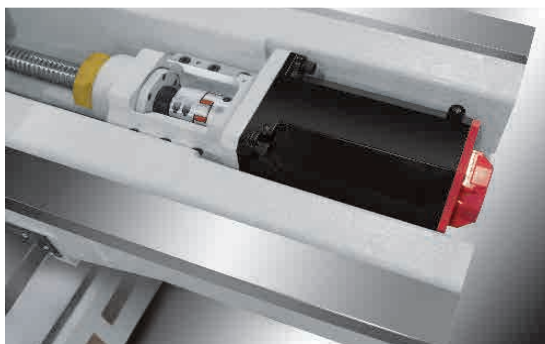

- 3 axes are adopted with direct drive AC servo motor to ensure great heavy load ability and provide high dynamic accuracy and fast acceleration/deceleration.



- C3 class ball screw with double nuts ensures optimal accuracy and long lasting. Besides, pre-tension design on all axes eliminates thermal deformation to ensure outstanding machining accuracy.

SUPER RIGID STRUCTURE

M860 / M1100
/ M1320 / M1600 / M1600L

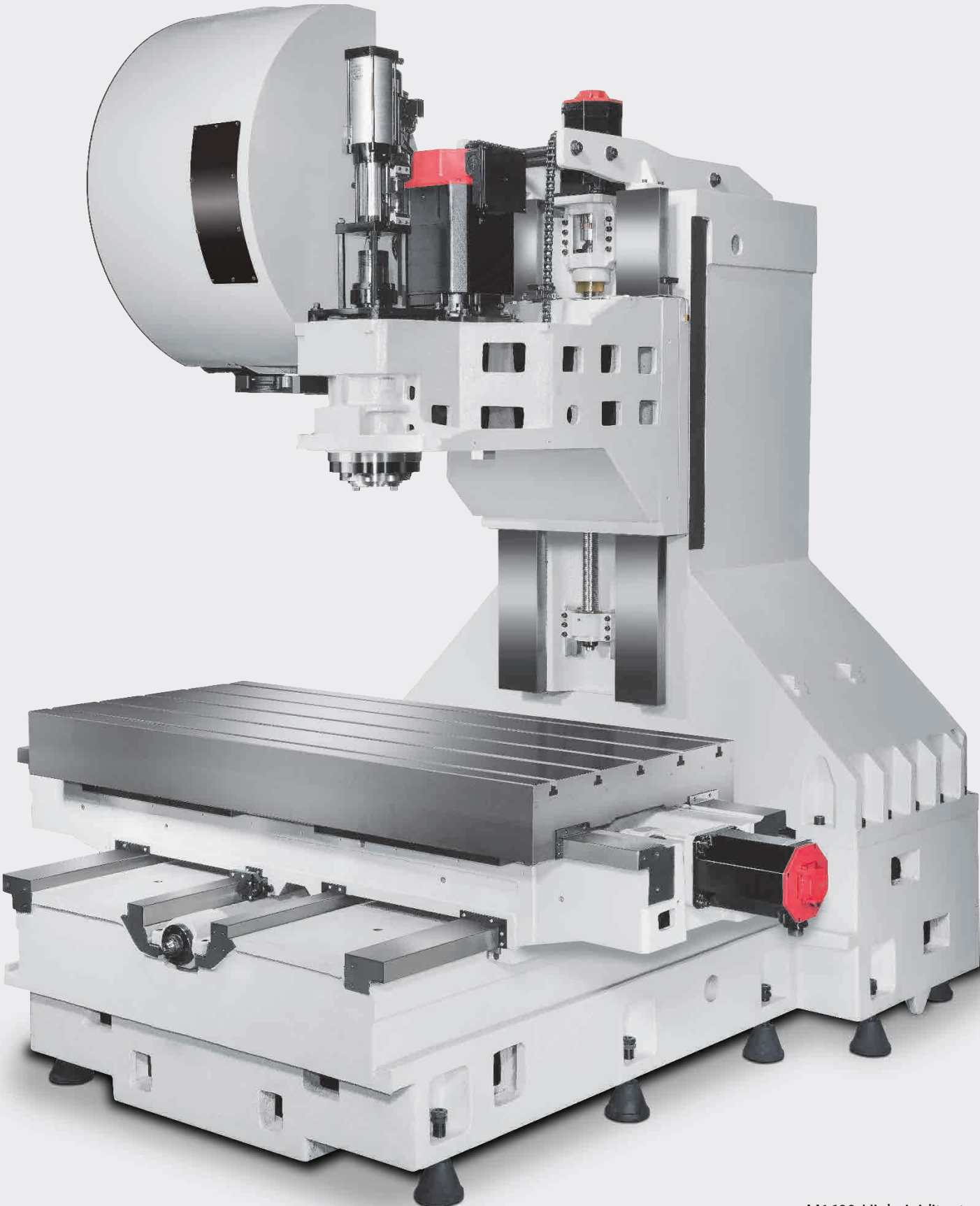

M1600 High rigidity structure

Unique Spindle System

- Depend on machining characteristics, gear drive system provides high torque machining, or high speed direct drive system is also available for specific high accuracy dies & molds machining.
- High speed 15,000 rpm direct drive spindle provide high machining accuracy due to isolating heat from motor.
- Equipped 2-step German made ZF gear box provides high torque heavy cutting capability at low rpm. (Option L1060 / L1320)
- Spindle frame is adopted enforced steel alloy and 3 sets of bearing. Spindle motor runs through dynamic balancing to ensure quality is beyond G0.4 high accuracy balancing according to ISO 1940 standard while ensuring spindle run-out less than 0.003mm.



All series are standard with spindle chiller to eliminate thermal deformation and ensure high accuracy and long lasting.

BT 40 15,000 rpm Direct drive Spindle

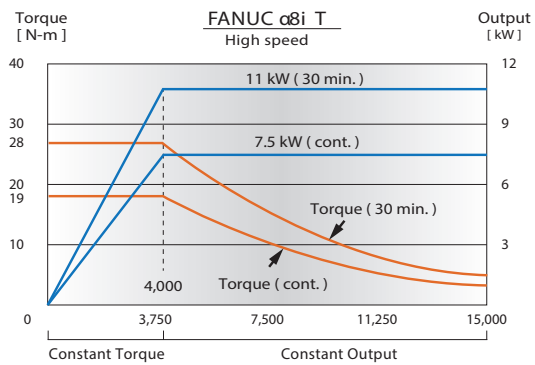
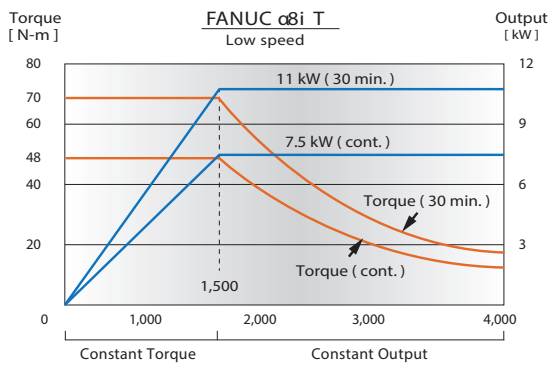

BT 40 8,000 rpm Belt drive Spindle

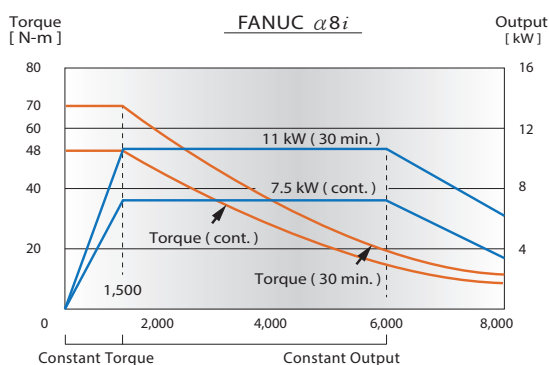

BT 40 8,000 rpm ZF Gear drive

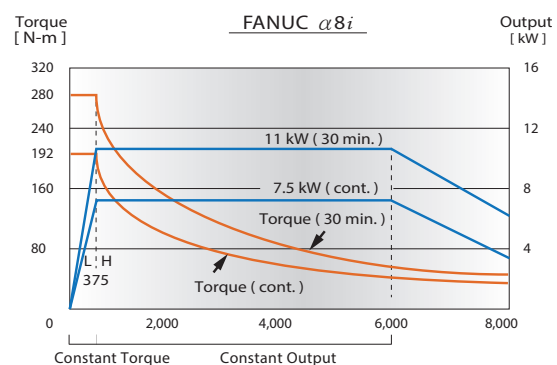

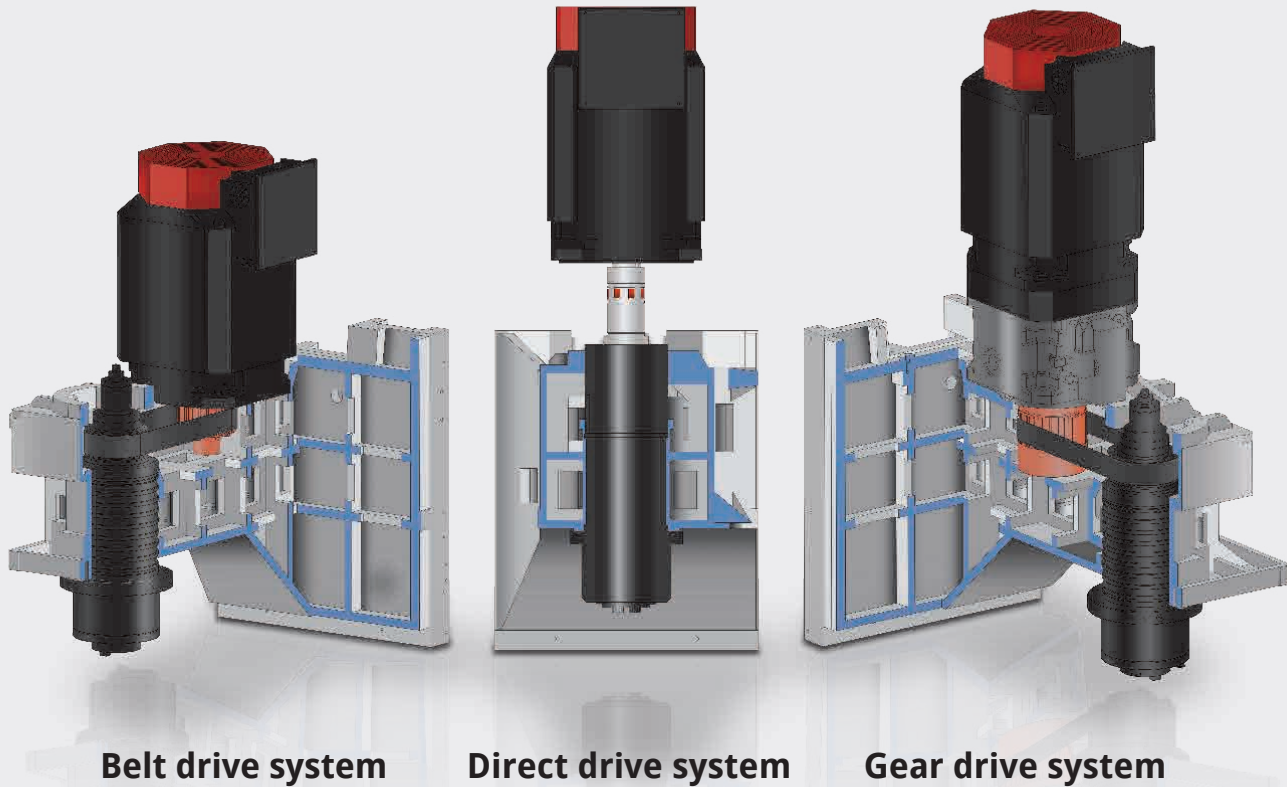

BT 40 10,000 rpm Belt drive Spindle

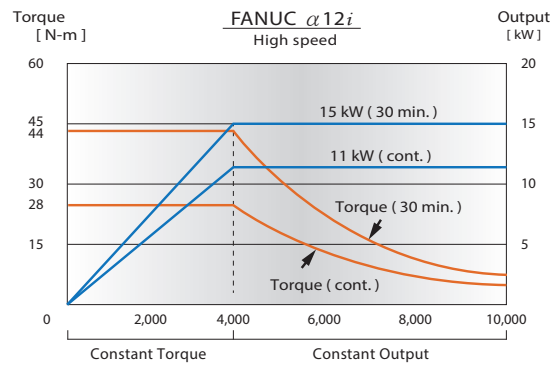
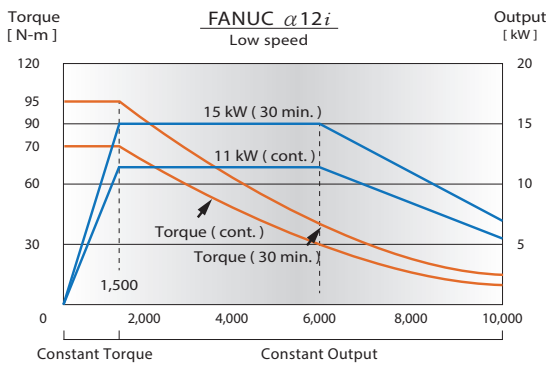

BT 40 8,000 rpm Belt drive Spindle

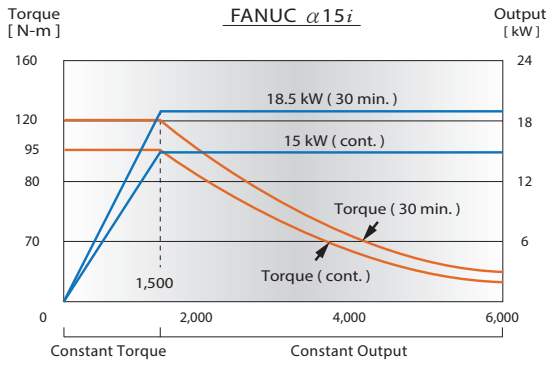

BT 40 6,000 rpm ZF Gear drive

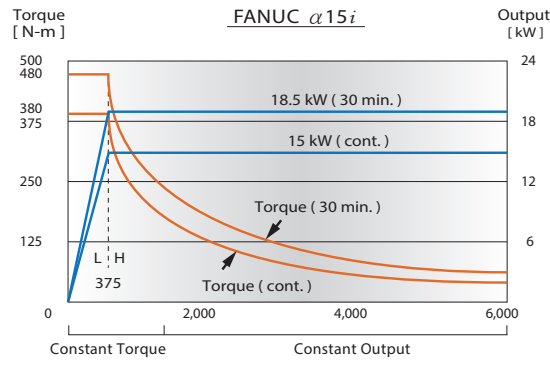

Fast and Reliable ATC System



- Equipped with high efficiency ATC system which provides reliable and smooth tool changing without delay.



High Efficiency Chips Removal

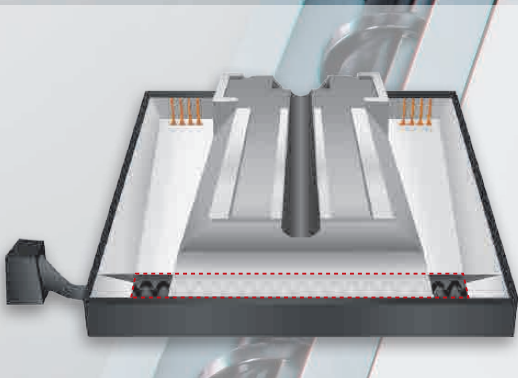

■ Side exit type

High pressure chips flush coolant
Screw type chip auger x 1

M860 M1100 M1320

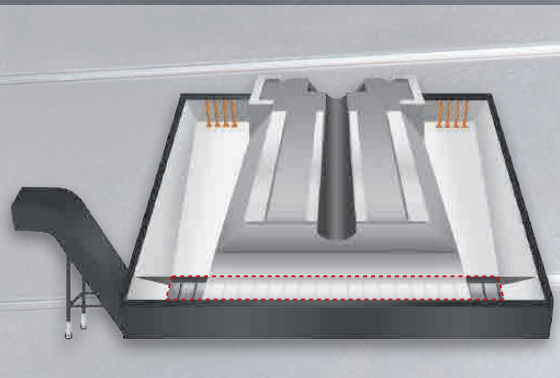

■ Side exit type Option

High pressure chips flush coolant
Caterpillar type chip conveyor

M860 M1100 M1320

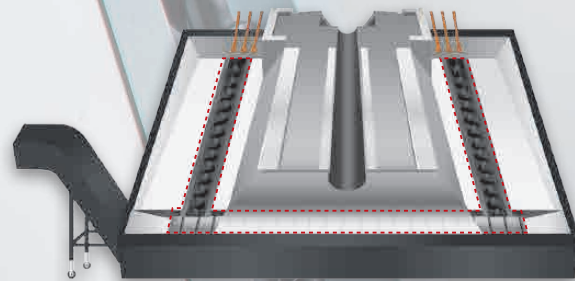
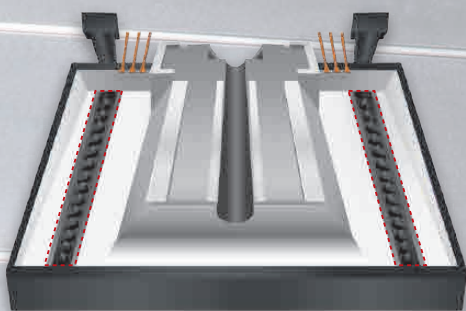

■ Rear exit type

High pressure chips flush coolant
Screw type chip auger x 2

M1600 M1600L

■ Rear exit type **Option**

High pressure chips flush coolant
Screw type chip auger x 2
Caterpillar type chip conveyor

M1600 M1600L

Dimensions

Table Dimensions



Model	A	B	C	D
M860	984	500	130	55
M1100	1,260	600	120	60
M1320	1,520	700	145	60
M1600	1,800	800	165	70
M1600L	1,800	800	165	70

T-slot Dimensions

(Unit : mm)

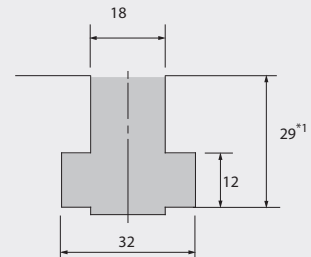

*1 36 (M1600 / M1600L)

Machine Dimensions M860 / M1100 / M1320

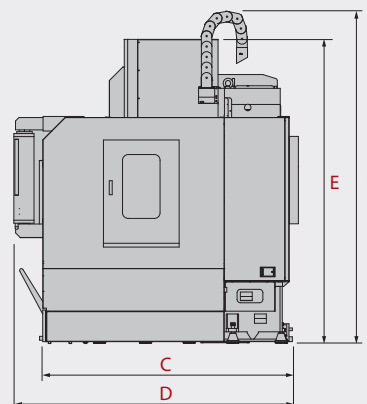
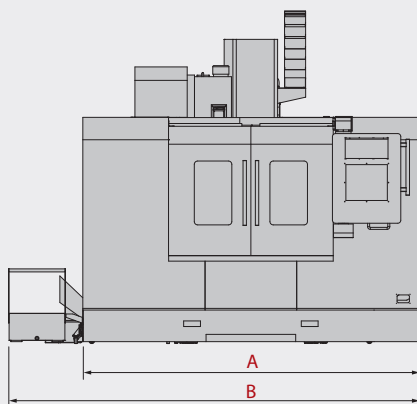
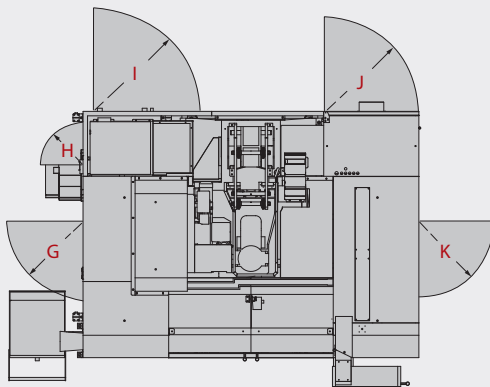

Model	A	B	C	D	E	F	G	H	I	J	K
M860	2,960	3,615	2,380	2,535	2,695	2,925	700	-	400	850	700
M1100	3,000	3,660	2,280	2,540	2,710	3,060	680	380	950	845	750
M1320	3,360	3,960	2,720	2,875	2,760	2,970	700	-	400	850	700

Tool Shank and Pull Stud Dimensions

(Unit : mm)

BT40

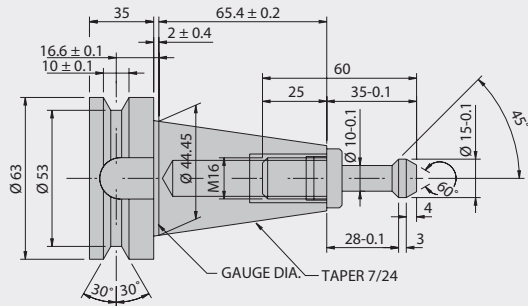

BT50

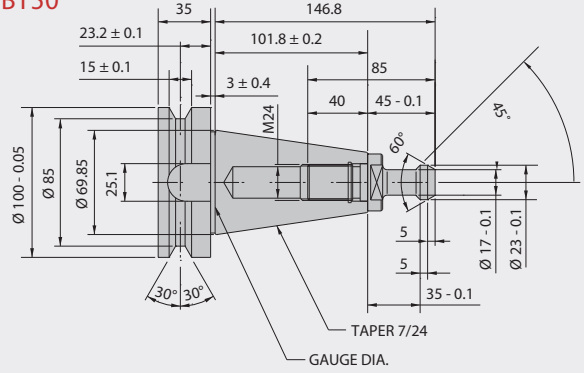

CAT40

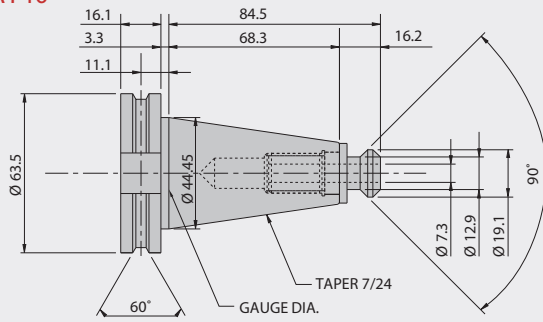

CAT50

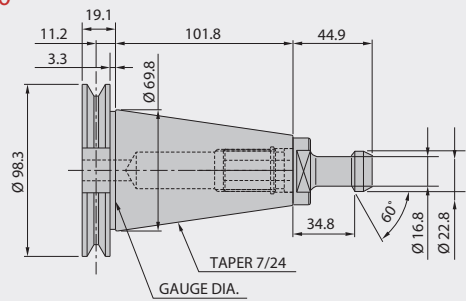

Machine Dimensions

M1600 / M1600L

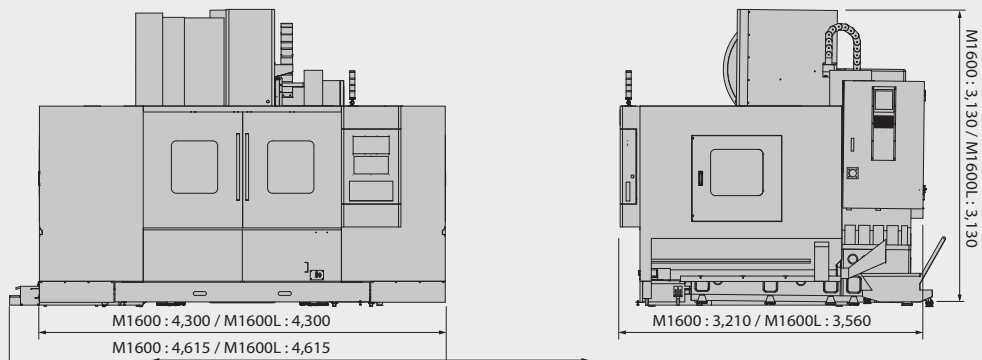
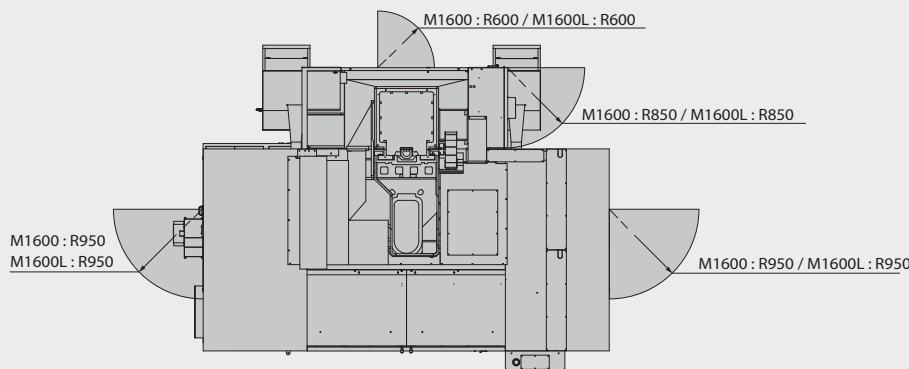

SPECIFICATIONS		M860	M1100
X-axis travel	mm	860	1,100
Y-axis travel	mm	510	610
Z-axis travel	mm	610	700
Distance from spindle center to column	mm	590	650
Distance from spindle nose to table top	mm	150 ~ 760	140 ~ 840
WORKING TABLE			
Table size	mm	984 x 500	1,260 x 600
T-slot (width x no. x space)	mm	18 x 4 x 130	18 x 5 x 120
Table load capacity	kg	900	1,000
SPINDLE			
Spindle motor (cont. / 30 min)	kW	7.5 / 11	
Spindle speed	rpm	Belt drive 8,000 (Opt. 10,000) Direct drive 10,000 (Opt. 12,000 / 15,000 / 20,000)	Belt drive 8,000 (Opt. 10,000) Direct drive 10,000 (Opt. 12,000 / 15,000 / 20,000) Gear drive 6,000 (Opt. 8,000)
Spindle taper		# 40	# 40
FEED RATE			
X / Y / Z axes rapid feed rate	m/min.	24 / 24 / 16	
Cutting feed rate	m/min.	10	
TOOL MAGAZINE			
Tool magazine capacity	T	Carousel type 16 (Opt. Arm type 24)	Arm type 24 (Opt. 30 / Carousel type 20T)
Max. tool diameter / adj. pocket empty	mm	Ø 78 / Ø 150	
Max. tool length	mm	300	
Max. tool weight	kg	7	
ACCURACY			
Positioning accuracy (JIS B 6338)	mm	± 0.010 / Full Travel	
Positioning accuracy (VDI 3441)	mm	P ≤ 0.010 / Full Travel	
Repeatability (JIS B 6338)	mm	± 0.003	
Repeatability (VDI 3441)	mm	Ps max ≤ 0.005	
GENERAL			
Control system		FANUC / MITSUBISHI / SIEMENS / HEIDENHAIN	
Power requirement	kVA	32	
Pneumatic pressure requirement (min.)	kg/cm ²	5 ~ 8 (5)	
Coolant tank capacity (pump)	liter	240 (1)	
Machine weight	kg	4,500	6,500

Standard Accessories

Spindle chiller	Centralized automatic lubricating system	Alarm light
Coolant nozzles around spindle	Chips flush coolant system	Halogen work light
Fully enclosed splash guard	Air gun system	Operation manual
Coolant system with pump and tank	Automatic power off system	Adjusting tools & tool box
Screw type chip auger	Leveling bolts & pads	

M1320		M1600	M1600L
1,320		1,600	1,600
710		800	1,000
700		800	800
755		860	1,060
# 40 : 130 ~ 830	# 50 : 94 ~ 794	170 ~ 970	
1,520 x 700		1,800 x 800	
18 x 5 x 145		18 x 5 x 165	
1,500		2,000	
11 / 15	15 / 18.5 (Opt. 18.5 / 22)	15 / 18.5 (Opt. 18.5 / 22)	
Belt drive 8,000 (Opt. 10,000) Direct drive 10,000 (Opt. 12,000 / 15,000 / 20,000) Gear drive 6,000 (Opt. 8,000)	Belt drive 8,000 Gear drive 6,000 (Opt. 8,000)	Belt drive 6,000 / 8,000 (Opt. 4,500 / 8,000 / 10,000) Direct drive 15,000 Gear drive 4,500 (Opt. 6,000)	
# 40	# 50	# 40 / # 50	
24 / 24 / 16		18 / 18 / 12	
10		10	
Arm type 24 (Opt. 30 / Carousel type 20T) Ø 80 / Ø 150	Arm type 24 (Opt. 30 / Chain type 40) Ø 125 / Ø 150	Arm type 24 (Opt. 30 / Chain type 40) Ø 80 / Ø 150 or Ø 125 / Ø 200	
300		300 / 400	
7	15	7 / 15	
± 0.010 / Full Travel		± 0.010 / Full Travel	
P ≤ 0.010 / Full Travel		P ≤ 0.015 / Full Travel	
± 0.003		± 0.003	
Ps max ≤ 0.005		Ps max ≤ 0.007	
FANUC / MITSUBISHI / SIEMENS / HEIDENHAIN			
42	48	48	
5 ~ 8 (5)		5 ~ 8 (5)	
240 (1)		280 (1)	
8,500		14,000	

Specifications are subject to change without notice.

Optional Accessories

ZF gear box	Oil skimmer	CNC rotary table
15,000 rpm direct drive spindle	Oil mist system	AC cooler for electrical cabinet
Coolant through spindle (20 bar)	Automatic tool length measurement	Caterpillar type chip conveyor
X / Y / Z axes optical linear scale	Automatic work-piece measurement	Automatic voltage regulator