



THE ULTIMATE MACHINING POWER

**YIH CHUAN MACHINERY
INDUSTRY CO., LTD**

HEADQUARTERS

40755 No.8, 9th Rd., Taichung Industrial Park,
Taichung, Taiwan

T e l : +886-4-2359-3351

F a x : +886-4-2359-0012

E-mail : extron@extroncnc.com

**YIH CHUAN MACHINERY
(JIAXING) INDUSTRY CO., LTD**

CHINA BRANCH

314031 No.3198, Zhongshan West Rd.,
Xiuzhou Industrial Area, Jiaxing, Zhejiang

T e l : +86-573-8279-9488

F a x : +86-573-8279-7299

E-mail : yihchuan@extroncnc.com



EXTRONCNC.com

LH Series

High Performance
Horizontal Machining Centers

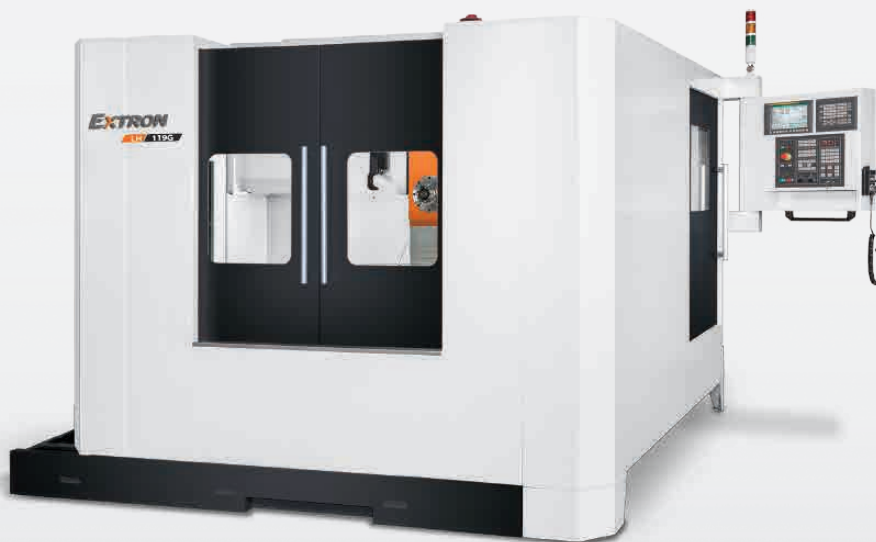

EXTRON

THE ULTIMATE MACHINING POWER

With 40 years experience of manufacturing machine tools, EXTRON has continuously developed and provided creative machine tools for global customers. We're always looking for solutions to improve our products and give you the better quality, reliable machines and service.

- High torque gear spindle can easily achieve machining requirements of heavy cutting. (LH-119G series)



HIGH PERFORMANCE HORIZONTAL MACHINING CENTERS

LH-75R / LH-75I / LH-119 / LH-119R
LH-119I / LH-119GR / LH-119GI

The LH series featured with high torque spindle, servo motor, indexing rotary table and arm type tool magazine which provide optimal machining capabilities to fulfill your requests in the future.

- All axes use high speed linear guide ways to offer super rigidity and superior acceleration / deceleration performance.
- Equipped with arm type 24T ATC system ensures reliability and efficiency.
- Coolant nozzles around spindle featured with high efficiency chips removal design ensures the outstanding machining accuracy.
- Compact exterior design saves floor space as well as lower shipping cost while travel.

Operation space at the side of machine



- The Meehanite casting structure provides solid support and capable of performing heavy cutting.
- One-piece wide span structure of column offers structural stiffness and superior cutting rigidity while shifting headstock in high speed.
- By carrying the weight of tool magazine and tools on casting body can enforce reliability of tool change and extend usage of tool magazine.

Structure of Bed

- Super rigidity 4 linear guide ways on bed fulfill machining needs of heavy cutting. Meantime, symmetrically central driven design, which ball screw locates at center of moving trail on Z-axis, provides high accuracy and heavy load axial system.

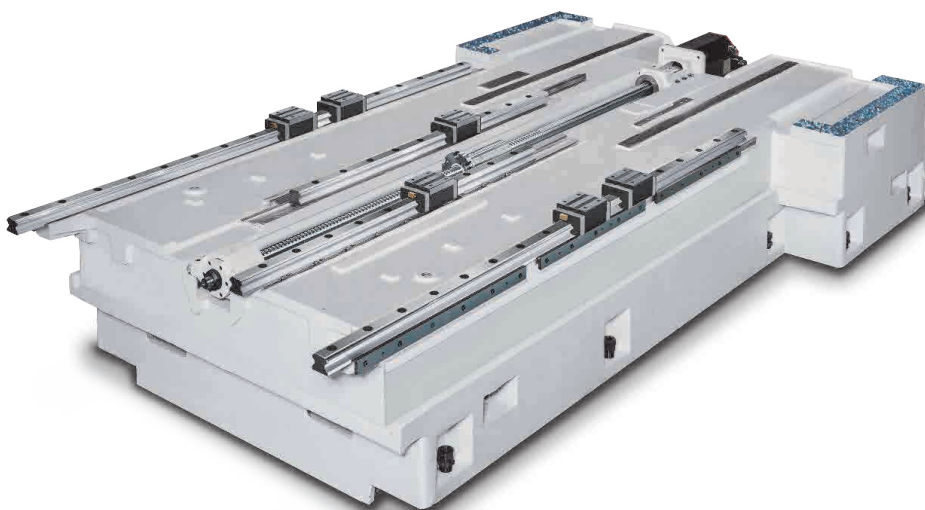

SUPER RIGID STRUCTURE

LH-75R / LH-75I / LH-119 / LH-119R
LH-119I / LH-119GR / LH-119GI

- The Finite Element Analysis (FEA) is used on all castings to ensure high stiffness and minimize deformation.

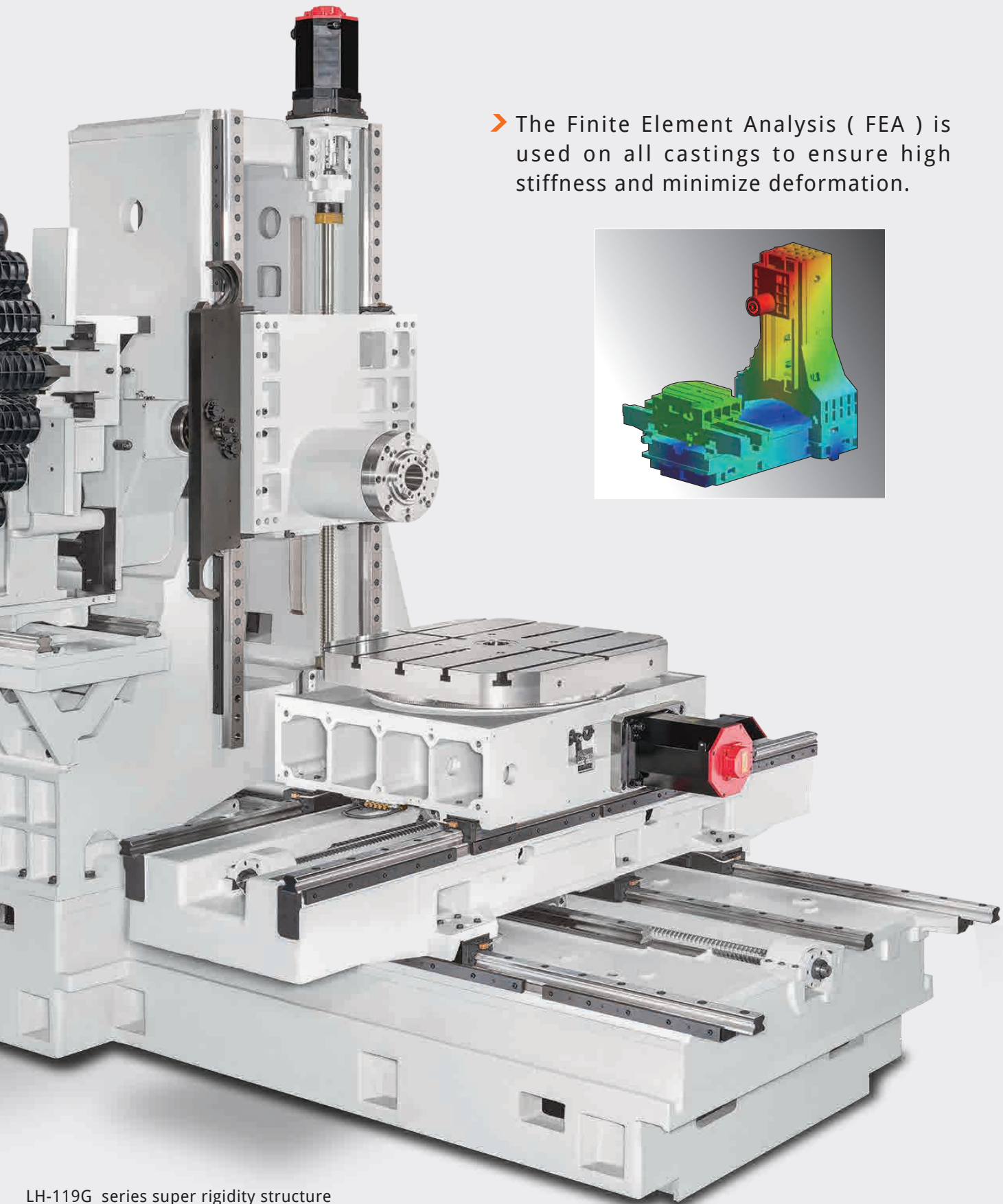
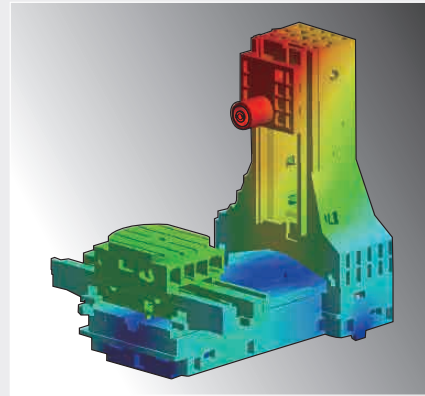

LH-119G series super rigidity structure

Long Nose Spindle

- Efficiently shortening the distance between tool and work-piece minimizes the overhanging of tool.

Ball Screw

- C3 class ball screw with double nuts ensures optimal accuracy and long-lasting. Besides, pre-tension design on all axes eliminates thermal deformation to ensure outstanding machining accuracy.

Direct drive Servo Motor

- 3 axes are adopted direct drive servo motor to provide great thrust and fast movement.

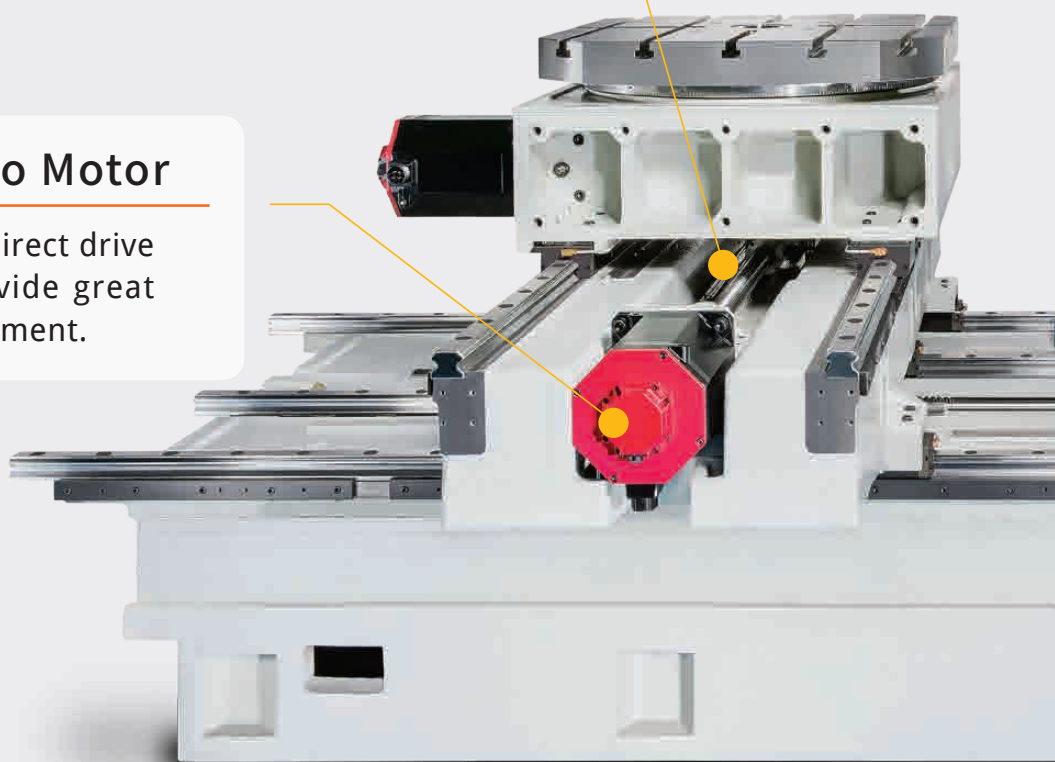

HIGH PERFORMANCE HORIZONTAL MACHINING CENTERS

LH-75R / LH-75I / LH-119 / LH-119R
LH-119I / LH-119GR / LH-119GI



Non-counter Weight Design

- Non-counter weight balancing with brake system on Y-axis offers rapid movement and ensures machining accuracy.

Heavy Load Linear Blocks

- 3 sets (6 pcs) of roller type linear guide way block design on Y-axis minimizes vibration and enhances rigidity of headstock to ensure peak machining performance and accuracy. (LH-119 series)

36 / 30 / 36 m/min

X / Y / Z rapid feed rate

Enforced Cross Ribs Design

- The massive structure of bed, column, and table are all adopted with enforced cross ribs design that offers the best stability and precision for constantly machining.

LH-119G series super rigidity structure

Unique Spindle System

- High torque gear spindle and high value belt drive spindle provides various machining needs.
- All series are standard with spindle oil chiller system to eliminate thermal deformation and ensure high accuracy and long lasting.
- High value belt drive spindle design offers various selections of motors to suit your machining needs.
- 8,000 rpm high value spindle equipped FANUC α i12 spindle motor (BT40) provides powerful 15 kW output. Equipped FANUC α i15 spindle motor (BT50) provides powerful 18.5 kW output.

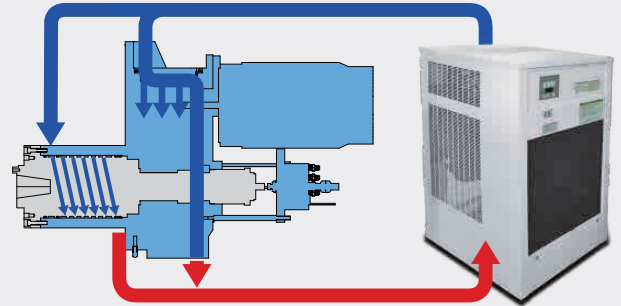

LH-119G series gear spindle

471 N-m
Max. Torque

- Equipped high torque gear spindle enhances heavy cutting capability. (LH-119G series)
- 2-speeds super heavy-duty gear box.
- 4,500 rpm high torque spindle equipped FANUC α i15 spindle motor (BT50) provides powerful 18.5 kW motor delivers maximum torque output of 471 N-m at 375 rpm.

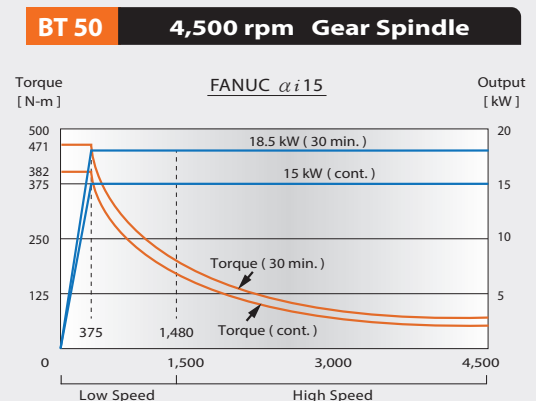

High Efficiency Rotary Table

- Depend on different machining requirements, 1° and 0.001° indexing / rotary table can fulfill various type of processing needs.
- CNC 0.001° indexing / rotary table equipped with two-piece worm gear system provides high accuracy simultaneous machining capabilities, mostly use of spiral machining, and aerospace industry.

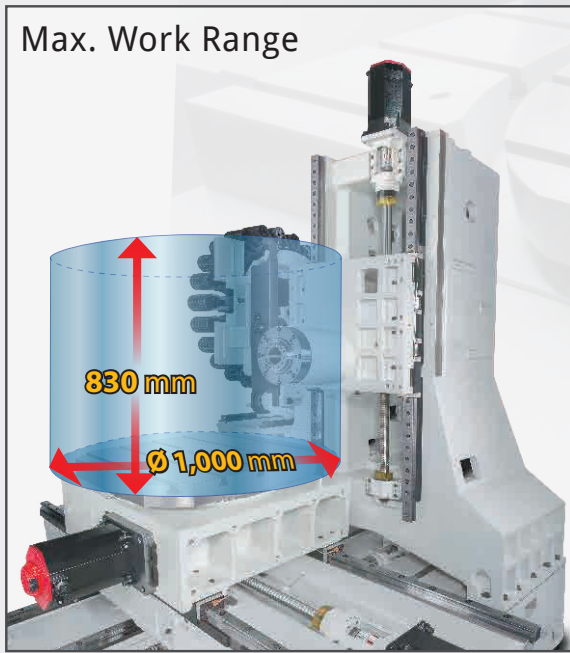

1,200 kg
Max. Load Capacity

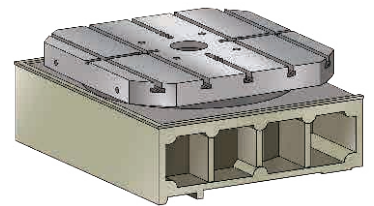
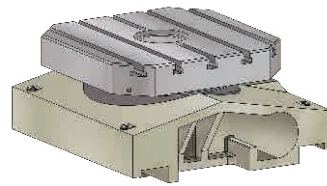
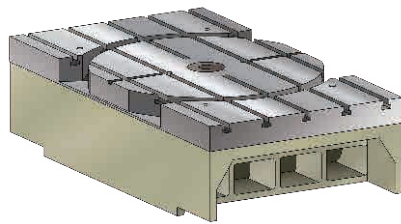
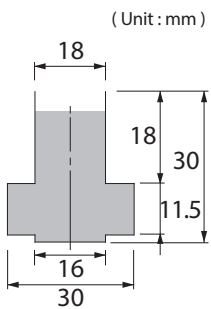

| Model | LH-119 | LH-75R LH-75I | LH-119R LH-119GR LH-119I LH-119GI |
|----------------------------|-------------|---------------|-----------------------------------|
| Table Size | 1,260 x 700 | 500 x 500 | 700 x 700 |
| Indexing table (B -axis) | 740 x 700 | 500 x 500 | 700 x 700 |
| 1° Pos. Accuracy | 10 | 10 | 10 |
| 1° Rep. Accuracy | 2 | 2 | 2 |
| 0.001° Pos. Accuracy | - | 15 | 15 |
| 0.001° Rep. Accuracy | - | 6 | 4 |

ATC System

- All series are equipped with efficient arm type 24 tool ATC system which provides smooth tool changing without delay. (T-T : 1.9 second)
- Two types of magazines, moveable and immovable. Moveable magazine can efficiently enlarge working range and prevent hazards caused by spray of coolant.
- Chain type 40 tool ATC system is also available for option.



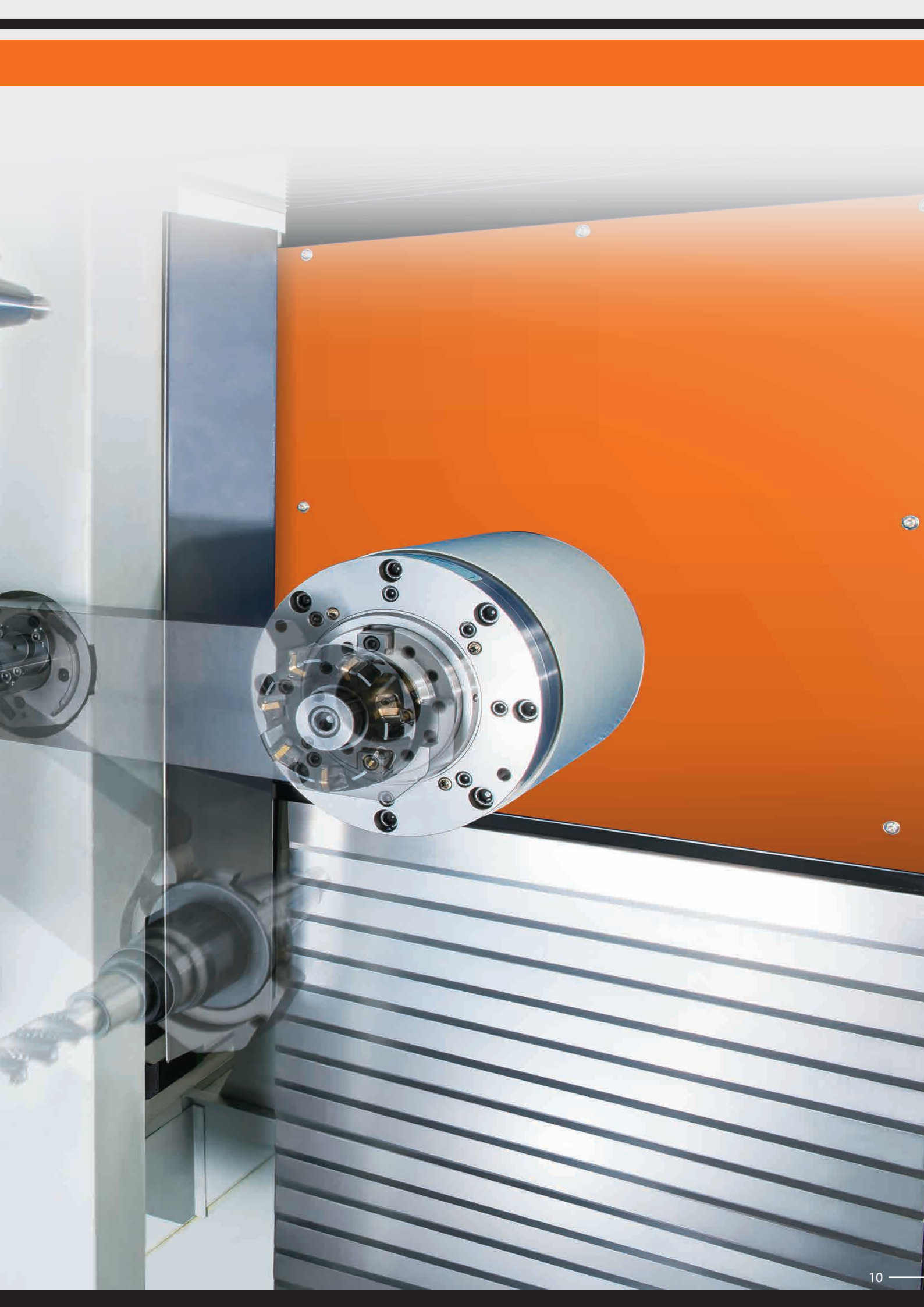

Coolant And Chips Conveyor

Coolant system

- All series features powerful coolant nozzles around spindle as standard provides high efficiency chips removals ability and decreases the rise of temperature to remain machining accuracy.
- Coolant through spindle, which not only extends long lasting of tools, but also fulfills machining requests of deep hole drilling and milling, is available for option.

Chip removal system

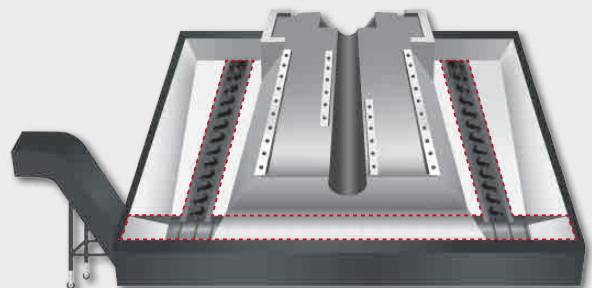
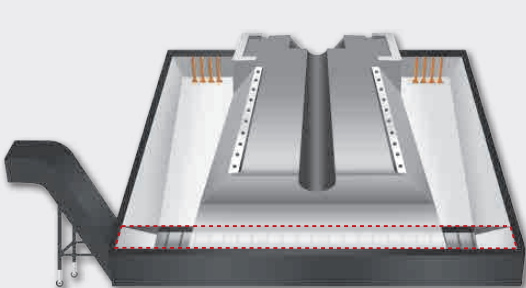
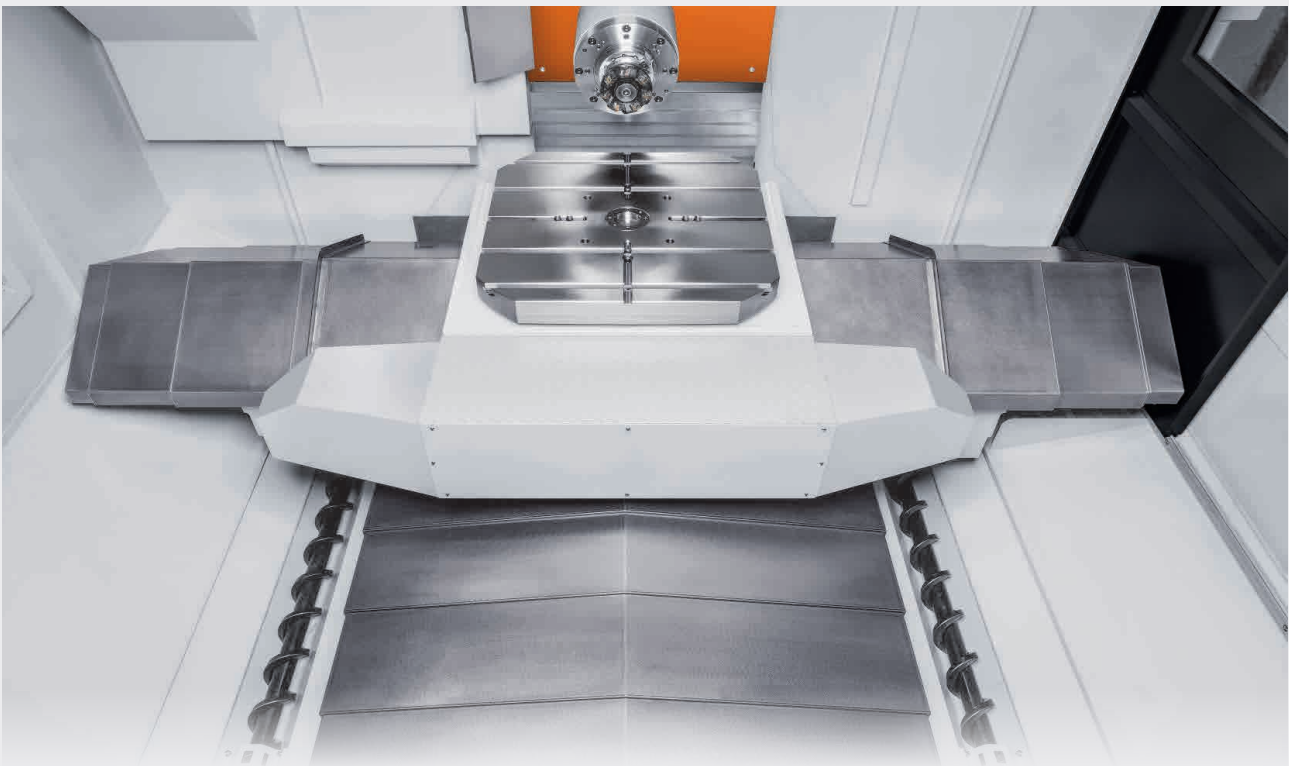

■ Side exit type

High pressure chips flush coolant
Caterpillar type chip conveyor

LH-75R

LH-75I

■ Side exit type

Screw type chip auger x 2
Caterpillar type chip conveyor

LH-119 LH-119R LH-119I LH-119GR LH-119GI

Dimensions

Tool Shank and Pull Stud Dimensions

(Unit : mm)

BT40

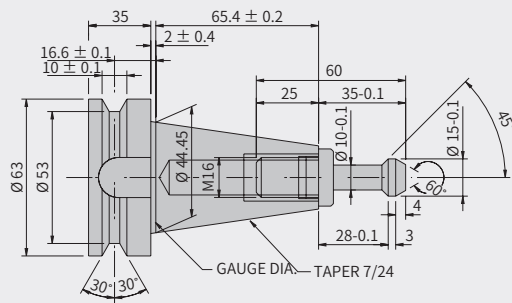

BT50

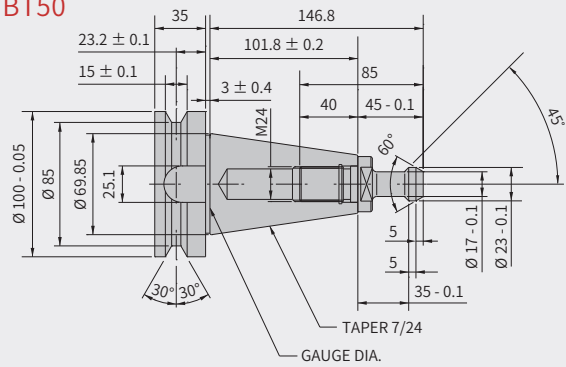

CAT40

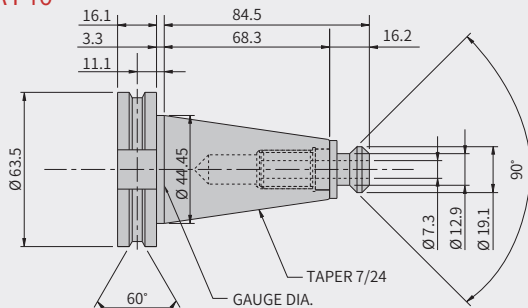

CAT50

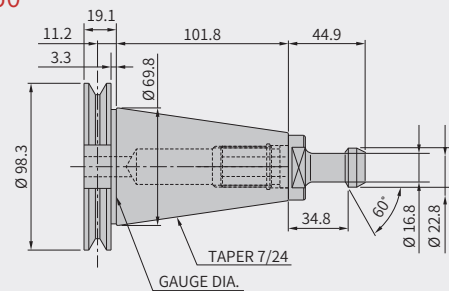

Machine Dimensions

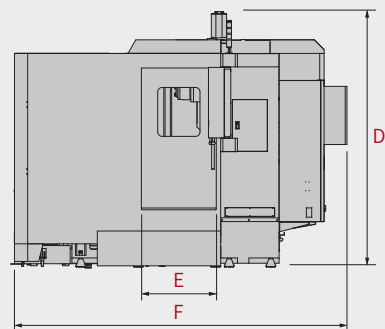
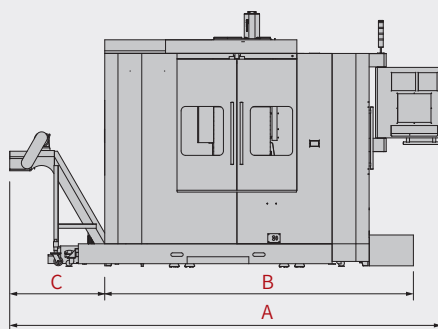
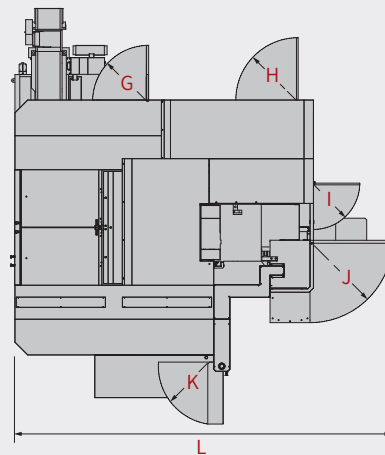

| Model | A | B | C | D | E | F | G | H | I | J | K | L |
|----------|-------|-------|-------|-------|-----|-------|-----|-----|-----|-----|-----|-------|
| LH-75R | 4,030 | 2,700 | 1,145 | 2,592 | 800 | 3,283 | 750 | 795 | 565 | 970 | 565 | 4,062 |
| LH-75I | 4,030 | 2,700 | 1,145 | 2,592 | 800 | 3,283 | 750 | 795 | 565 | 970 | 565 | 4,062 |
| LH-119 | 4,979 | 3,500 | 1,130 | 2,896 | 850 | 3,775 | 660 | 735 | 545 | 970 | 689 | 4,443 |
| LH-119R | 4,979 | 3,500 | 1,130 | 2,896 | 850 | 3,775 | 660 | 735 | 545 | 970 | 689 | 4,443 |
| LH-119I | 4,979 | 3,500 | 1,130 | 2,896 | 850 | 3,775 | 660 | 735 | 545 | 970 | 689 | 4,443 |
| LH-119GR | 4,979 | 3,500 | 1,130 | 2,896 | 850 | 3,775 | 660 | 735 | 545 | 970 | 689 | 4,443 |
| LH-119GI | 4,979 | 3,500 | 1,130 | 2,896 | 850 | 3,775 | 660 | 735 | 545 | 970 | 689 | 4,443 |

| SPECIFICATIONS | | LH-75R | LH-75I |
|--|--------|---|------------------|
| X-axis travel | mm | 700 | |
| Y-axis travel | mm | 660 | |
| Z-axis travel | mm | 625 | |
| Distance from spindle nose to table center | mm | 122 ~ 747 | |
| Distance from spindle nose to column | mm | 302 | |
| Distance from spindle center to table | mm | 0 ~ 660 | |
| Distance from floor surface to table surface | mm | 1,056 | |
| WORKING TABLE | | | |
| Table size | mm | 500 x 500 | |
| Indexing table (B-axis) | mm | 500 x 500 | |
| T-slot (width x no. x space) | mm | 18 x 5 x 100 | |
| Table load capacity | kg | 500 | |
| Max. work-piece height | mm | 660 | |
| Min. indexing angle | degree | 0.001 | 1 |
| SPINDLE | | | |
| Spindle motor (cont. / 30 min) | kW | 11 / 15 | 15 / 18.5 |
| Spindle speed | rpm | Belt drive 8,000 (Opt. 6,000 / 10,000) | Belt drive 6,000 |
| Spindle taper | | # 40 | # 50 |
| FEED RATE | | | |
| X / Y / Z axes rapid feed rate | m/min. | 36 / 30 / 36 | |
| Cutting feed rate | m/min. | 10 | |
| TOOL MAGAZINE | | | |
| ATC type | | Arm type | |
| Tool magazine capacity | T | 24T | |
| Max. tool diameter | mm | Ø 78 / Ø 150 | Ø 105 / Ø 220 |
| Max. tool length | mm | 300 | 350 |
| Max. tool weight | kg | 7 | |
| ACCURACY | | | |
| Positioning accuracy (JIS B 6338) | mm | ± 0.005 / Full travel | |
| Repeatability (JIS B 6338) | mm | ± 0.003 | |
| GENERAL | | | |
| Control system | | FANUC / MITSUBISHI / SIEMENS / HEIDENHAIN | |
| Power requirement | kVA | 43 | |
| Coolant tank capacity | liter | 250 | |
| Machine weight | kg | 6,600 | |
| Floor Space (L / W / H) | mm | 2,850 / 3,283 / 2,592 | |

Standard Accessories

| | | |
|-----------------------------------|--|--------------------|
| Spindle air blast | Centralized automatic lubricating system | Alarm light |
| Spindle chiller | Arm type 24 tool ATC system | Halogen work light |
| Coolant nozzels around spindle | Air gun system | Operating manual |
| Fully enclosed splash guard | Adjusting tools and tool box | Mechanical manual |
| Coolant system with pump and tank | Automatic power off system | Electrical manual |
| Catepillar type chip conveyor | Leveling bolts & pads | |

| LH-119 | | LH-119R | | LH-119I | | LH-119GR | | LH-119GI | |
|-------------|--|---|--|---------|--|---|--|----------|--|
| | | 1,100 | | | | 1,100 | | | |
| | | 800 | | | | 800 | | | |
| | | 900 | | | | 900 | | | |
| | | 100 ~ 1,000 | | | | 100 ~ 1,000 | | | |
| | | 441 | | | | 441 | | | |
| | | 10 ~ 810 | | | | 10 ~ 810 | | | |
| | | 1,166 | | | | 1,166 | | | |
| 1,260 x 700 | | 700 x 700 | | | | 700 x 700 | | | |
| 740 x 700 | | 700 x 700 | | | | 700 x 700 | | | |
| | | 18 x 5 x 145 | | | | 18 x 5 x 125 | | | |
| 800 | | 1,200 | | | | 1,200 | | | |
| | | 810 | | | | 810 | | | |
| 1 | | 0.001 | | 1 | | 0.001 | | 1 | |
| | | 15 / 18.5 | | | | 15 / 18.5 | | | |
| | | Belt drive 6,000 (Opt. 4,500 / 8,000) | | | | Gear drive 4,500 (Opt. 6,000) | | | |
| | | # 50 | | | | # 50 | | | |
| | | 36 / 30 / 36 | | | | 36 / 30 / 36 | | | |
| | | 10 | | | | 10 | | | |
| | | Arm type (Opt. Moveable arm type) | | | | Moveable arm type | | | |
| | | 24T (Opt. 40T) | | | | 24T (Opt. 40T) | | | |
| | | Ø 125 / Ø 250 | | | | Ø 125 / Ø 250 | | | |
| | | 300 (Opt. 400) | | | | 300 (Opt. 400) | | | |
| | | 15 | | | | 15 | | | |
| | | ± 0.005 / Full travel | | | | ± 0.005 / Full travel | | | |
| | | ± 0.003 | | | | ± 0.003 | | | |
| | | FANUC / MITSUBISHI / SIEMENS / HEIDENHAIN | | | | FANUC / MITSUBISHI / SIEMENS / HEIDENHAIN | | | |
| | | 55 | | | | 55 | | | |
| | | 390 | | | | 390 | | | |
| 10,500 | | 10,700 | | | | 11,000 | | | |
| | | 4,979 / 3,775 / 2,896 | | | | 4,979 / 3,775 / 2,896 | | | |

Specifications are subject to change without notice.

Optional Accessories

| | | |
|------------------------------------|------------------------------------|--------------------------------------|
| Oil skimmer | Air condition for electric cabinet | Automatic voltage regulator |
| Coolant through spindle (20 bar) | Chain type 40 tool ATC system | Moveable arm type 24 tool ATC system |
| Automatic tool length measurement | Transformer | X / Y / Z axes optical linear scale |